

1(6)

UDC 696.1

PIPE IN TUBE SYSTEMS

Key words: Pipes, tube systems, test method

1 SCOPE

This Nordtest method specifies test methods for testing complete Pipe in tube systems for fitness in use. The systems consist of an inner PEX pipe, an outer protection pipe, couplings, rubber seals, sleeves, wall boxes, other bushings and manifold cupboards.

The tests described here include testing of:

- Outer protection pipe
- Fixing sleeves and end sleeves
- Rubber seals
- Wall boxes, bushings
- Manifold cupboards
- Exchangeability of the inner pipe.

2 FIELD OF APPLICATION

The test methods can be used by the manufacturers as a tool for developing new products, and as a basis for official approval in the Nordtest member countries.

The intention is that this method will not prevent the process of product development, and only concerns functional testing of Pipe in tube systems.

3 REFERENCES

NT VVS 072	Overflow
NT BUILT 448	Watertightness
KIWA BRL 5606	Plastics piping systems of PE-X.
EN 681/1	Quality of rubber sealings
DIN 4060	Quality of rubber sealings.

4 DEFINITIONS

Cold Water:	Water at a temperature <20 °C
Room temperature:	23 ± 5 °C
Low temperature:	$-5 \pm 0,5$ °C

5 SAMPLING

The tests in this Nordtest standard are carried out on:

- 3 samples for each test described for testing outer protection pipe, except the 6.4.5.1, where only 1 sample shall be tested.
- 3 samples for each test described for testing wall boxes and bushings
- 3 samples for each test described for testing fixing sleeves and end sleeves
- 1 sample for each test described for testing rubber seals
- 1 sample for each test described for testing manifold cupboards
- 1 complete system for exchangeability.

The test pieces are chosen at random from the normal production line.

6 METHOD OF TEST

6.4.0 Marking

The following tests are carried out on the outer protection pipe. The PEX pipe is removed:

- 6.4.1 Determination of compression resistance
 - 6.4.1.1 Compression resistance combined with low temperature
- 6.4.2 Resistance to impact combined with low temperature
- 6.4.3 Resistance to bending combined with low temperature
- 6.4.4 Strength test
- 6.4.5 Pressure test on fixing sleeves and end sleeves
 - 6.4.5.1 Pressure test on protection pipe.

The following tests are carried out on rubber seals:

- 6.4.6 Watertightness.

The following tests are carried out on wall boxes and bushings:

- 6.4.6 Watertightness
- 6.4.7 Watertightness of wallbox, and connection between box and protection pipe
- 6.4.8 Resistance to pull out of the protection pipe.

The following tests are carried out on manifold cupboards:

- 6.4.9 Watertightness by internal splashing
- 6.4.10 Watertightness of the bushings
- 6.4.11 Water capacity of the drain
- 6.4.12 Resistance to pull out of the protection pipe

The following tests are carried out for exchangeability:

- 6.4.13 Exchangeability of the inner PEX pipe
- 6.4.14 Watertightness of the protection pipe.

6.1 Principle

Pipe in tube systems are delivered as a complete system, and shall be watertight and exchangeable.

They are tested as a unit, and all parts are delivered from the same supplier.

The systems can be delivered with either a pipe manifold mounted on a room with a gully, or a manifold cupboard mounted in a wall, with a drain to a gully or a suitable drain system.

6.2 Apparatus

The individual tests are carried out in special test set-ups, shown in figures.

The accuracy of the measuring instruments shall be as described in Section 6.6.

6.3 Preparation of test samples

The test samples are checked against drawings and descriptions, and are mounted according to the manufacturer's instructions.

6.4 Procedure

The following is a description of the procedures for each of the tests.

6.4.0 Marking

The wall box must be provided with the manufacturer's name or identity symbol, and the manifold cupboard shall be marked in a clearly visible place when it is mounted in the installation.

6.4.1 Determination of compression resistance

3 test pieces, each with a length of 100 ± 1 mm, are prepared at room temperature for 15 minutes.

A diametral load of 250 N, evenly distributed over the length, is gradually (≈ 10 mm/min) applied to each specimen. See Figure 1.

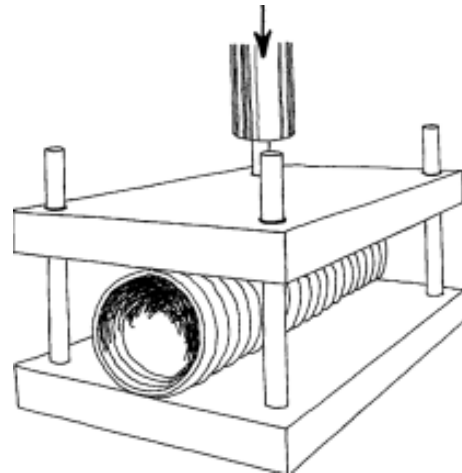

Fig. 1.

5 minutes after the load of 250 N is applied, the outside diameter of the test specimen across the centre of the load axis is measured. The flattening shall not exceed 20% of the original outside diameter.

The load is then released, and the test specimens are allowed to rest for 1 minute. The outside diameter of the test piece shall then have returned to at least 90% of its original diameter.

After measuring these diameters, the specimens are pressure tested with water at 10 kPa, and no leakages shall be visible during a period of 5 minutes.

6.4.1.1 Compression resistance combined with low temperature

The same arrangement as described above, with 3 new test pieces.

The test shall be made in a room or other suitable place at a temperature of -5 °C. The 3 test specimens shall be conditioned at this temperature for 1 hour.

5 minutes after the load of 250 N is applied, it is released, and the test specimens shall exhibit no fractures or cracks.

The test pieces are brought to a room at room temperature, and pressure tested with water at 10 kPa. No leakages shall be visible during a period of 5 minutes.

6.4.2 Resistance to impact

3 test pieces, each with a length of 100 ± 1 mm, are prepared in a room or other suitable place at a temperature of -5 °C. The falling weight shall have a spherical impact face and a weight of 255 ± 5 g. The radius of the weight shall be 20 ± 1 mm.

The protection pipe, up to 28 mm outside diameter, is placed on a V-shaped supporting block with an angle of 120° . See Figure 2.

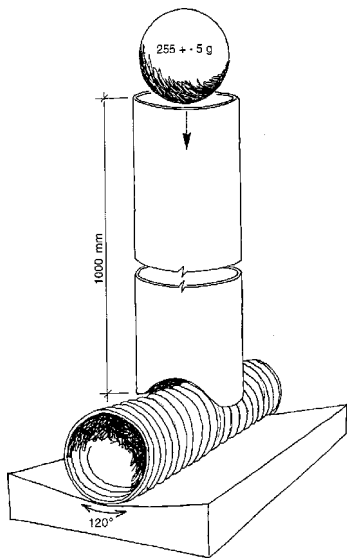

Fig. 2.

The test shall be made in a room or other suitable place, at a temperature of $-5\text{ }^{\circ}\text{C}$.

The 3 test specimens shall be conditioned at this temperature for 1 hour.

The test piece is placed on the supporting block, and a guide pipe device is arranged so that the falling weight hits the centre of the test specimen. The drop is 1000 mm.

The test specimens shall exhibit no fractures or cracks.

The test pieces are brought to a room at room temperature and pressure tested with water at 10 kPa. No leakages shall be visible during a period of 5 minutes.

6.4.3 Resistance to bending

3 test pieces, each with a length of $750 \pm 4\text{ mm}$, are prepared in a room or other suitable place at a temperature of $-5\text{ }^{\circ}\text{C}$. Templates with a radius of 4 x the outside diameter of the protection pipe are required. See Figure 3.

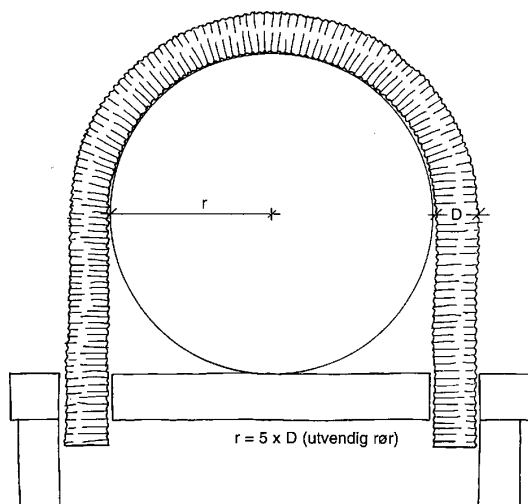

Fig. 3.

The test shall be made in a room or other suitable place, at a temperature of $-5\text{ }^{\circ}\text{C}$. The 3 test specimens shall be conditioned at this temperature for 1 hour.

The test samples shall be bent by hand through 180° around the template.

The test specimens shall exhibit no fractures or cracks.

The test pieces are brought to a room at room temperature and pressure tested with water at 10 kPa. No leakages shall be visible during a period of 5 minutes.

6.4.4 Strength test

3 test pieces, each of $50 \pm 1\text{ mm}$ length, are prepared at room temperature for 15 minutes. They are cut in two longitudinally.

An apparatus with the means to apply and record a vertical load is needed.

A flat ended steel probe is mounted on the apparatus. The diameter of the steel probe is 0,75 mm, length $\geq 10\text{ mm}$. The test pieces are placed on a styrofoam or soft rubber sheet, with a thickness of $\approx 10\text{ mm}$. See Figure 4.

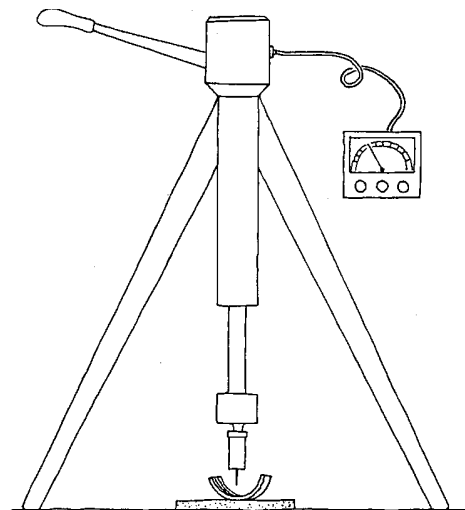

Fig. 4.

The steel probe is forced onto the surface of the test piece, in the bottom of the corrugation, and the force needed to penetrate the pipe is recorded. The force should be $\geq 40\text{ N}$.

6.4.5 Pressure test on fixing sleeves and end sleeves

The test shall be made in a room at room temperature. The 3 test specimens shall be conditioned at this temperature for 1 hour.

A protection pipe, length 3000 mm, is attached to each side of the fixing sleeve. A fixing sleeve is used to splice two protection pipes, or repair a damage.

The end sleeves are mounted to a corrugated pipe on one side, and to a 10 mm Cu pipe on the other. (An end sleeve is the one used between the corrugated pipe and the 10 mm Cu pipe of the sink mixer. The coupling is inside the sleeve.)

The system is filled up with cold water, and the pressure of 30 kPa shall be kept for 5 minutes. No leakages shall occur during the period.

6.4.5.1 Pressure test on protection pipe

The test shall be made in a room at room temperature. 1 coil of protection pipe shall be conditioned at this temperature for 1 hour.

The protection pipe, with a length of ≥ 25 metres, shall be mounted to a pump system at one end, and plugged at the other.

The pressure of 50 kPa shall be kept for 5 minutes. No leakages shall occur during the period.

6.4.6 Watertightness

A hole for the wallbox or bushing is made in a pressed wallboard, dimension 1000 x 1000 mm.

The wallbox or bushing is mounted according to the recommendations of the manufacturer. The rubber seal is placed on the box, and liquid membrane is used on the rubber seal, and shall cover the whole pressed wallboard in correct thickness.

The liquid membrane shall dry for the time recommended by the producer.

For the boxes and bushings meant as mounting brackets for bath/shower mixers, a rod is screwed into their threaded connection.

A static load of 200 N, at a distance of 100 mm from the wall, is applied.

A hand shower, giving 0,15 l/s, is placed in front of the arrangement. The water shall hit ≈ 150 mm above the box, and at the same time, the water shall cover more than the area of the rubber seal. The following procedure is carried out:

1. Hot water, 50 °C, for one minute.
2. One minute pause
3. Cold water for one minute
4. One minute pause.

These cycles are repeated 300 times.

No leakages shall occur between the rubber seal and the wallbox, and between the rubber seal and liquid membrane.

For walls with an outside membrane, like vinyl wallpaper, the same temperature cycling test shall be made for the boxes and bushings meant for wet zones.

The quality of the rubber seals shall be according to: EN 681/1 or DIN 4060.

O-rings used in the wall boxes, or other rubber devices, shall be according to the same standards.

6.4.7 Watertightness of the wallbox, and connection between box and protection pipe

The test shall be made at room temperature, and without inner pipe.

The protection pipe, with a length of 3000 mm, is mounted to the wallbox, according to the producer's description. The alignment is then altered: 250 mm from the connection point, the protection pipe is bent 80 mm, as shown in Figure 5.

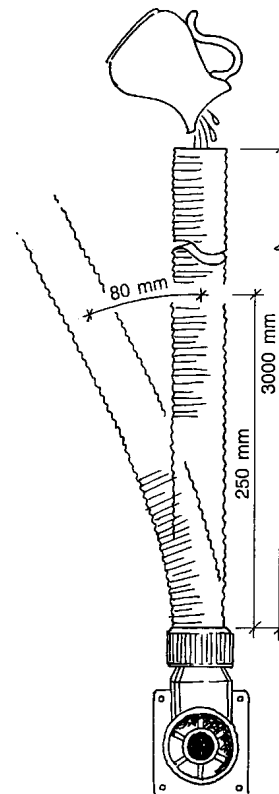

Fig. 5.

The outlet of the box is sealed, and water is poured into the whole length of the protection pipe.

The test can also be made using a pump. The pressure at the connection between the box and the protection pipe shall be 30 kPa.

No leakages shall be visible during a period of 5 minutes.

6.4.8 Resistance to pull out

The test shall be made at room temperature, and without inner pipe.

The protection pipe, with a length of ≈ 300 mm, is mounted to the wallbox, according to the producer's description. The box is fixed firmly to a wall, and a force or load of 100 N is applied in the longitudinal direction, to see if the protection pipe is firmly fixed to the box.

The outer pipe should not slip or loosen from the box, during a period of 5 minutes.

6.4.9 Watertightness by internal splashing

The test shall be made at room temperature.

The drain pipe shall be drawn through the bushings according to the manufacturer's instructions. The test is made with the door of the manifold cupboard closed.

A copper pipe with sufficient small holes can be used as water supply, so that the whole inner surface of the manifold comes in contact with water.

The water flow shall be $\approx 0,20$ l/s.

No visible leakages shall occur during a period of 5 minutes.

6.4.10 Watertightness of bushings

The test shall be made at room temperature, and with at least 4 bushings for water connection, and the drain bushing mounted in the bottom of the manifold cupboard. Protection pipes and drain pipe shall be drawn through the bushings according to the manufacturer's instructions. An alteration of alignment, with dimensions as described in 6.4.7, is made on the protection pipes, on the under side of the manifold cupboard.

The bottom of the manifold cupboard is filled up with water to 10 mm below the level that causes overflow.

No visible leakages shall occur during a period of 5 minutes.

6.4.11 Water capacity of the drain

The test shall be made at room temperature. The drain pipe shall be drawn through, or fixed to, the bushing, according to the manufacturer's instructions.

Water is supplied and the water flow is increased, until the bottom of the manifold cupboard is filled up with water, – and the level is steady, 10 mm below the level that causes overflow.

The drain shall have a capacity of $\geq 0,25$ l/s.

6.4.12 Resistance to pull out of the protection pipe

The test shall be made at room temperature, and without inner pipe.

The protection pipe, with a length of ≈ 300 mm, is mounted to the manifold cupboard, according to the producer's description. A force or load of 100N is applied, to see if the protection pipe is fixed firmly to the manifold cupboard.

The outer pipe should not slip or loosen during a period of 5 minutes.

6.4.13 Exchangeability of the inner PEX pipe

The test shall be made at room temperature. A stud partition, like the one in Figure 6 is built. One wallbox is fixed at a height of 500 mm to a pressed wallboard, and 4 90°

bends are made on the pipe, inclusive the one in the wallbox. The two bends of the pipe section shall have a radius of 100 mm. Pipe clips are used every 600 mm, – the distance between the studs.

The total lengths of the pipe, shall be 10 metres. The exchangeability shall be tested according to the manufacturer's instructions.

The withdrawal of the PEX pipe starts from the box side. It is often necessary to start the withdrawal with one or two powerful pulls.

When the PEX pipe shall be replaced, a tongue with a length of 150 mm is made by knife on the PEX pipe.

This replacement of the inner PEX pipe should be possible without damaging the corrugated pipe or arrangement.

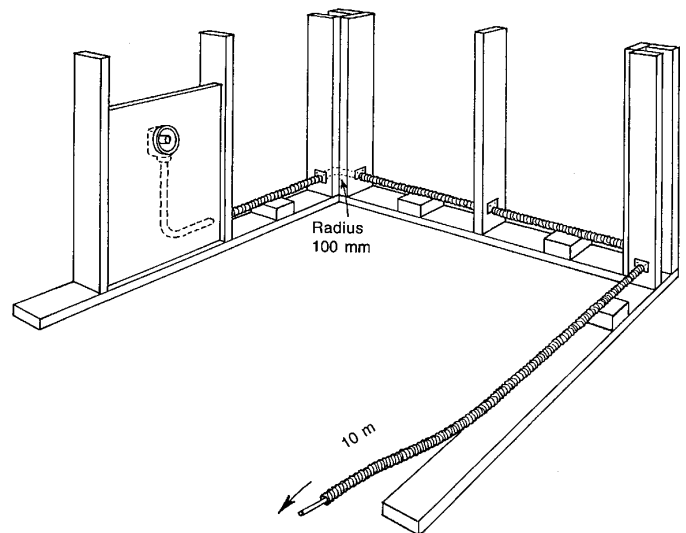

Fig. 6.

6.4.14 Watertightness of the protection pipe

After the test, described in 6.4.13, and same arrangement, the end of the corrugated pipe is plugged, and the system is filled up with cold water from the box side, and the pressure of 5 kPa shall be kept for 5 minutes. No leakages shall occur during the period.

6.5 Expression of Results

All results must be presented in the following units, so that test results from different laboratories are directly comparable.

Length:	millimetre = mm
Flow rate:	litres per second = l/s
Pressure:	kilo pascal = kPa, 100 kPa = 1 bar
Temperature:	degrees Celsius = °C
Force:	kilo Newton = kN.

6.6 Accuracy

The pressure shall be measured with an accuracy of $\pm 3\%$.

The water flow rate shall be measured with an accuracy of $\pm 3\%$.

The temperature shall be measured with an accuracy of ± 2 °C.

6.7 Test Report

The test report shall include the following information, if relevant:

- a) Name and address of the testing laboratory.
- b) Identification number of the test report
- c) Name and address of the organisation or the person who ordered the test.
- d) Purpose of the test.
- e) Method of sampling and other circumstances.
(Date and person responsible for the sampling.)
- f) Name and address of manufacturer or supplier of the tested object.
- g) Name or other identification marks of the tested object.
- h) Description of the tested object.
- i) Date of supply of the tested object.
- j) Date of the test.
- k) Test method
- l) Conditioning of the test specimens, environmental data during the test. (Temperature, pressure, RH, et.)
- m) Identification of the test equipment and instruments used.
- n) Any deviation from the test method
- o) Test results (use SI units, see Section 6.5)
- p) Accuracy of the test results
- q) Date and signature